

FRD

WOOD CHIPPER OWNER'S MANUAL

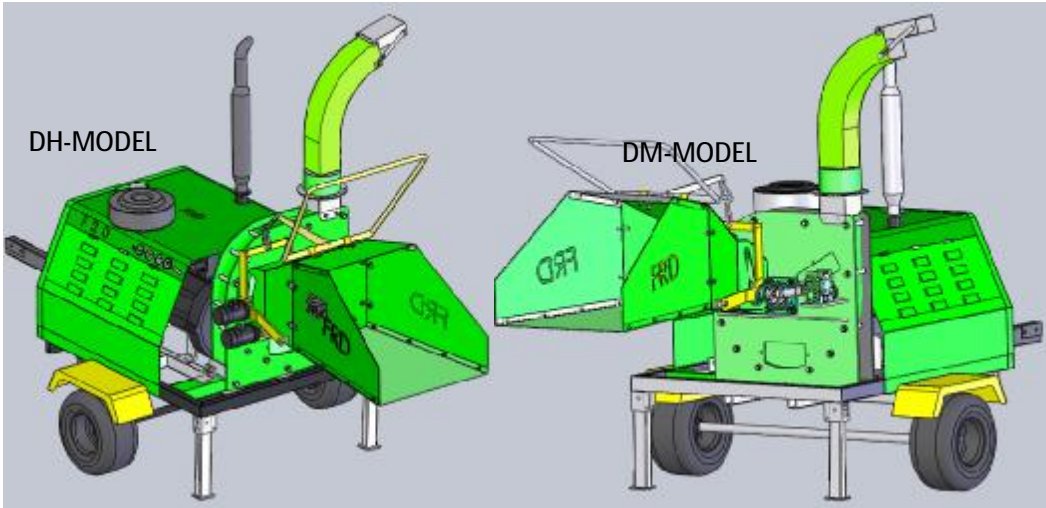
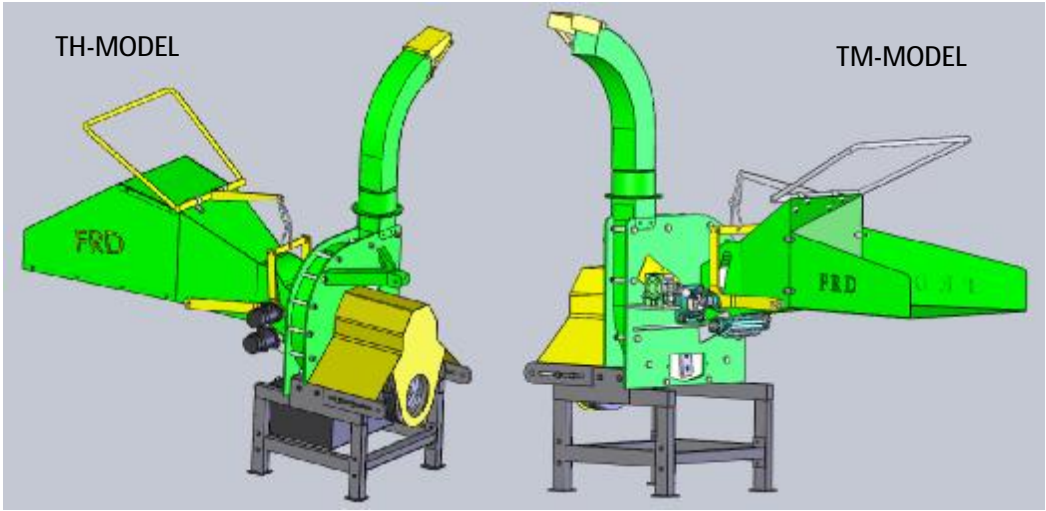

DEAR FRD COMPANY CUSTOMER

Thank you for purchasing a FRD COMPANY product. The FRD COMPANY (Weifang FRD Machinery Co., Ltd) line is designed, tested, and manufactured to give years of dependable performance. To keep your machine operating at peak efficiency, it is necessary to adjust it correctly and make regular inspections. The following pages will assist you in the operation and maintenance of your machine. Please read and understand this manual before operating.

If you have any questions or problems with your machine, please call or write your local factory-authorized FRD COMPANY dealer.

This document is based on information available at the time of its publication. FRD COMPANY is continually making improvements and developing new equipment. In doing so, we reserve the right to make changes or add improvements to our product without obligation for equipment previously sold.

CONTENTS

LIMITED WARRANTY.....	5
1 SAFETY SECTION.....	5
1.1 SAFETY ALERT.....	5
1.2 BEFORE OPERATING.....	5
1.3 OPERATION SAFETY.....	6
1.4 PTO SAFETY.....	7
1.5 FEED ROLLER SAFETY.....	7
1.6 MAINTENANCE AND STORAGE SAFETY.....	7
1.7 TOWING SAFETY.....	8
1.8 BATTERY SAFETY.....	8
2 ASSEMBLY SECTION.....	8
2.1 HITCH ASSEMBLY.....	8
2.2 CHECKING/ADDING OIL TO ENGINE.....	9
2.3 CHECKING/ADDING/REPLACING HYDROLIC OIL TO TANK.....	10
2.4 CONNECTING THE BATTERY.....	10
2.5 ATTACHING THE CHIPPER CHUTE.....	10
2.6 REVERSING VALVE.....	12
2.7 DISCHARGE TUBE.....	12
3 FEATURES & CONTROLS SECTION.....	13
3.1 ENGINE THROTTLE.....	13
3.2 KEY SWITCH.....	13
3.3 DISCHARGE TUBE.....	13
3.4 FEED CHUTE.....	13
3.5 CHIPPER BLADES.....	13
3.6 FEED ROLLER CONTROL BAR.....	13
3.7 HITCH JACK.....	13

3.8 SAFETY CHAINS.....	13
3.9 3-POINT HITCH CONNECTIONS.....	14
3.10 PTO SHAFT.....	14
4 OPERATION SECTION.....	14
4.1 STARTING ENGINES.....	14
4.2 STOPPING ENGINES.....	14
4.3 STARTING TRACTORS.....	15
4.4 STOPPING TRACTORS.....	15
4.5 CHIPPING GUIDE.....	15
5 SERVICE & MAINTENANCE.....	15
5.1 MAINTENANCE SCHEDULE.....	15
5.2 CHIPPER BLADES.....	17
5.3 REMOVING AND SHARPENING THE BLADES.....	17
5.5 DRIVE BELT ADJUSTMENT.....	18
5.6 TRAILER SERVICE TIPS.....	19
5.7 GREASING THE BEARINGS AND PIVOTS.....	19
6 TROUBLESHOOTING SECTION.....	19
7 SPECIFICATIONS SECTION.....	20
8. PRODUCT PATENT:.....	22

LIMITED WARRANTY

This warranty applies to Weifang FRD Machinery Co., Ltd(FRD COMPANY). FRD COMPANY warrants to the original owner each new product to be free defects in material and workmanship, under normal use and service.

In the event of a failure, return the product along with proof of purchase to the selling FRD COMPANY dealer. FRD COMPANY will, at its option, repair or replace any parts found to be defective in material or workmanship. Warranty on any repairs will not extend beyond the product warranty. Repair or attempted repair by anyone other than a FRD COMPANY dealer as well as subsequent failure or damage that may occur as a result of that work will not be paid under this warranty .FRD COMPANY does not warrant replacement components not manufactured or sold by FRD COMPANY.

1. This warranty applies only to parts or components that are defective in material or workmanship.
2. This warranty does not cover normal wear items including but not limited to bearings, belts, pulleys, filters and chipper knives.
3. This warranty does not cover normal maintenance, service or adjustments.
4. This warranty does not cover depreciation or damage due to misuse, negligence, accident or improper maintenance.
5. This warranty does not cover damage due to improper setup, installation or adjustment.
6. This warranty does not cover damage due to unauthorized modifications of the product.
7. Engines are warranted by the respective engine manufacturer and are not covered by this warranty.

FRD COMPANY is not liable for any property damage, personal injury or deaths resulting from the unauthorized modification or alteration of a FRD product or from the owner's failure to assemble, install, maintain or operate the product in accordance with the provisions of the Owner's manual.

FRD COMPANY makes no warranties, representations or promises, expressed or implied as to the performance of its products other than those set forth in this warranty. Neither the dealer nor any other person has any authority to make any representations, warranties or promises on behalf of FRD COMPANY or to modify the terms or limitations of this warranty in any way. FRD COMPANY, at its discretion, may periodically offer limited, written enhancements to this warranty.

FRD COMPANY RESERVES THE RIGHT TO CHANGE THE DESIGN AND/OR SPECIFICATIONS OF ITS PRODUCTS AT ANY TIME WITHOUT OBLIGATION TO PREVIOUS PURCHASERS OF ITS PRODUCTS.

1 SAFETY SECTION

1.1 SAFETY ALERT

The Owner/Operator's manual uses many symbols to alert you of potential hazards. Whenever you see these symbols, read and obey message that follows it. Failure to obey the safety message could result in personal injury, death or property damage.

1.2 BEFORE OPERATING

1.1.1 Read and understand this Owner/Operator's manual. Be completely familiar with the controls and the proper use of this equipment.

1.1.2 Familiarize yourself with all of the safety and operating decals on this equipment and on any of its attachments or accessories.

Keep safety decals clean and legible. Replace missing or illegible safety decals.

Obtain and wear safety glasses and use hearing protection at all times when operating this machine.

Avoid wearing loose fitted clothing. Never operate this machine wearing clothing with drawstrings that could wrap around or get caught in the machine.

Do not operate this machine if you are under the influence of alcohol, medications, or substances that can affect your vision, balance or judgment. Do not operate if tired or ill. You must be in good health to operate this machine safely.

Do not operate this equipment in the vicinity of by standers. Keep the area of operation clear of all persons, particularly small children. It is recommended that bystanders keep at least 50 feet (15 meters) away from the area of operation.

Do not allow children to operate this equipment.

Use only in daylight or good artificial light.

Do not run this equipment in an enclosed area. Engine exhaust contains carbon monoxide gas, a deadly position that is odorless, colorless tasteless. Do not operate this equipment in or near buildings, windows or air conditioners.

Always use an approved fuel container. Do not remove gas cap or add fuel when engine is running. Add fuel to a cool engine only.

Do not fill fuel tank indoors. Keep open flames, sparks, smoking materials and other sources of combustion away from fuel.

Do not operate machine without shields in place. Failure to do so may cause serious injury or death.

Keep all guards and shields in good working condition.

Before inspecting or servicing any part of the machine, shut off the machine, disconnect the battery, remove the ignition key and make sure all moving parts have come to a complete stop.

Check that all screws, nuts, bolts, and other fasteners are secured, tightened and in proper working condition before starting the machine and once every 8 hours of operation.

Do not transport or move machine while the machine is operating or running.

1.3 OPERATION SAFETY

Always stand clear of discharge area when operating this machine. Keep face and body away from feed and discharge openings.

Keep hands and feet out of feed and discharge openings while machine is operating to avoid serious personal injury. Stop and allow machine to come to a complete stop before clearing obstructions.

Set up your work site so you are not endangering traffic and the public. Take great care to provide adequate warnings.

Do not climb on machine when operating. Keep proper balance and footing at all times.

Check cutting chamber to verify it is empty before starting the machine.

The disk will continue to rotate when clutch is disengaged or reversing valves in the median. Shut off the machine, disconnect the battery, remove the ignition key and make sure all moving parts have come to a complete stop.

Do not insert branches large than 8 inches in diameter into chipper or machine damage may occur.

When feeding material into machine, do not allow metal, bottle, cans or any other foreign material to be fed into the machine.

Ensure debris does not blow into traffic, parked cars, or pedestrians.

Keep the machine clear of debris and other accumulations.

Do not allow processed material to build up in the discharge area. This may prevent proper discharge and can result in kick back of material through the feed opening.

Shut off machine immediately if the machine becomes clogged, the cutting mechanism strikes any foreign object, or the machine starts vibrating or making an unusual noise. Shut off the machine, disconnect the battery, remove the ignition key and make sure all moving parts have come to a complete stop. After machine stops:

Inspect for damage.

Replace or repair any damage parts.

Check for and tighten any loose parts.

On electric start models, disconnect cables from battery before doing any inspection or service. Remove the key.

Check blade bolts for proper torque after every 8 hours of operation. Check blades and rotate or sharpen daily or as required to keep blades sharp. Failure to do so may cause poor performance, damage or personal injury and will void the machine warranty.

1.4 PTO SAFETY

MODELS: TH-MODELS, TM-MODELS

1. Read and follow instructions on PTO safety decals.
2. Stay alert and pay attention when PTO is operating.
3. Keep bystanders, especially children, away from PTO driveline.
4. Check the driveline to ensure it is attached securely to the power supply.
5. Keep guards and shields in place at all times while operating. Disengage PTO, shut off power source, and make sure all moving parts have come to a complete stop before removing guards or shields.
6. Clothing worn by operator must be fairly tight. Never wear loose fitted jackets, shirts, or pants when working around the PTO. Tie long hair back or put under a cap.
7. Keep hydraulic hoses, chains and other items from contacting the driveline.
8. Do not exceed the recommended 540 RPM PTO operating speed.
9. Before inspecting or servicing the PTO drive area, disengage the driveline, shut off power source and make sure all moving parts have come to a complete stop.
10. Keep hands, feet, and clothing away from all PTO drive parts.
11. Do not clean, lubricate or adjust the PTO shaft when it is running.

1.5 FEED ROLLER SAFETY

MODELS: ALL MODELS

The feed roller can cause serious injury or death. Keep hands, feet and clothing away from the feed roller and chipper disk blades.

Never climb onto the feed chute when the unit is operating or running.

Do not over reach. Keep proper balance and footing at all times.

Never allow passengers to ride on the feed chute.

When feeding material into the feed roller, wear eye, face and hearing protection.

Release material and stand to side of feed chute.

1.6 MAINTENANCE AND STORAGE SAFETY

Before inspecting, servicing, storing, or changing an accessory, shut off the machine, disconnect the battery, remove the ignition key and make sure all moving parts have come to a complete stop.

Allow machine to cool before storing in an enclosure.

Store the machine out of reach of children and where fuel vapors will not reach an open flame or spark.

Never store the machine with fuel in the fuel tank inside a building where fuel can be ignited by an open flame or spark. Ignition sources can be hot water and space heaters, furnaces, clothes dryers, stoves, electric motors, etc.

1.7 TOWING SAFETY

Rotate the discharge tube to face the opposite direction of the towing vehicle before towing.

Insert transport safety pin and clip, and set turntable brake handle to locked position.

Connect hitch safety chains. Tighten and secure trailer hitch bolts.

Do not exceed maximum towing speed, indicated on tire sidewall. Inflate tires to manufacturers' specifications as state on the tire sidewall.

Optimum towing performance can be achieved by maintaining a horizontal trailer hitch.

Check wheel lug bolts periodically to ensure they are tight and secure.

Make sure the jack stand and the rear stabilizer on trailer are in the UP position during towing.

Never allow passengers to ride on the chipper.

If applicable, shut off fuel supply when towing.

1.8 BATTERY SAFETY

MODELS: DH-MODELS, DM-MODELS

Improper use and care of the battery on electric start models can result in serious personal injury or property damage. Always observe the following safety precautions.

Poison/Danger-Causes Severe Burns. The battery contains sulfuric acid. Avoid contact with skin, eyes or clothing. Keep out of reach of children.

ANTIDOTE-External Contact: Flush immediately with lots of water.

ANTIDOTE-Internal: Drink large quantities of water or milk. Follow with milk of magnesia, beaten egg or vegetable oil. Call a physician immediately.

ANTIDOTE-Eye contact: Flush with water for 15 minutes. Get prompt medical attention.

The battery can produce explosive gases. Keep sparks, flame or cigarettes away. Ventilate area when charging battery. Always wear safety goggles when working near battery.

The battery contains toxic materials. Do not damage battery case. If case is broken or damaged, avoid contact with battery contents.

Neutralize acid spills with a baking soda and water solution. Properly dispose of a damaged or worn-out battery. Check with local authorities for proper disposal methods.

Do not short circuit battery. Severe fumes and fire can result.

Before working with electrical wires or components, disconnect battery ground (negative) cable first. Disconnect positive cable second. Reverse this order when reconnecting battery cables.

2 ASSEMBLY SECTION

Before inspecting or servicing any part of this machine, shut off power source, remove key from the ignition and make sure all moving parts have come to a complete stop.

If any bolts or nuts are dropped in the machine, be sure to remove them before starting the machine. Remove items from the shredder area by removing the discharge screen.

2.1 HITCH ASSEMBLY

MODELS: DH-MODELS, DM-MODELS

1. Attach the hitch to the bottom of the trailer:

Attach the hitch on the end closest to the engine using four M12 (or 1/2") bolts, washers and nuts (Figure 2.1).

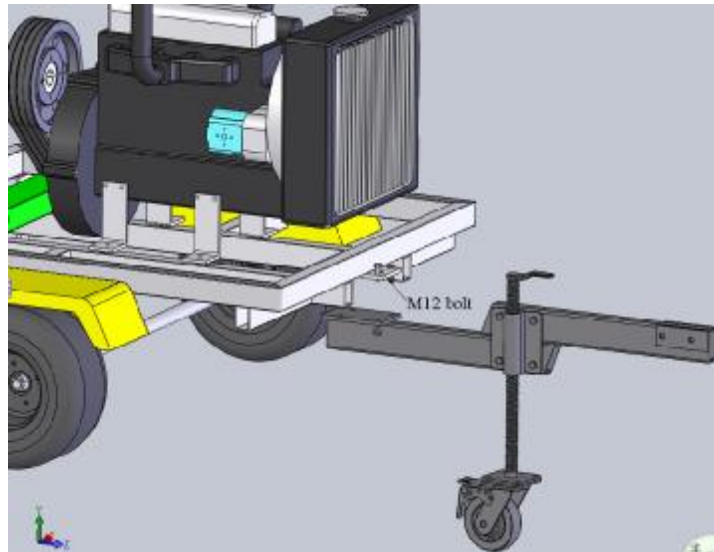

Figure 2.1 Attach the Hitch

2. Attach the coupler and the coupler handle onto the hitch pole using two M12 (or 1/2") bolts, washers and nuts (Figure 2.2).



Figure 2.2 Attach the Coupler

3. Attach the safety chains, one on each side of the hitch pole using one ring-pull.

2.2 CHECKING/ADDING OIL TO ENGINE

MODELS: DH-MODELS, DM-MODELS

Checking the oil level and, if needed, fill the engine crankcase with the type and amount of oil specified in the engine owner's manual.

Fuel is highly flammable and its vapors are explosive. To prevent personal injury or property damage, Store fuel only in approved containers, in well ventilated, unoccupied buildings, away from sparks or flames. Do not fill the fuel tank while the engine is hot or running. Spilled fuel could ignite if it comes in contact with hot parts or sparks from ignition. Do not start the engine near spilled fuel. Never use fuel as a cleaning agent.

For best results only clean, fresh fuel. Purchase fuel in small quantities and store in clean, approved

containers.

TO ADD DIESEL OIL

1. Stop engine, wait for all parts to stop moving and disconnect spark plug wire. Remove key from key switch. Allow the engine and muffler to cool for at least three minutes.

2. Clean area around fuel fill cap and remove cap.

3. Using clean fuel, fill fuel tank to 1/2" below bottom of filler neck to provide space for any fuel expansion.

Install fuel fill cap securely and wipe up any spilled oil.

Do not attempt to start the engine at this time. Wait until you have read the complete starting instructions in the Operation Section of this manual.

2.3 CHECKING/ADDING/REPLACING HYDROLIC OIL TO TANK

MODELS: DH-MODELS, TH-MODELS

Checking the hydraulic oil tank level and, if needed, fill the hydraulic oil tank with the type and amount of oil specified in the owner's manual (recommendation 46#HM hydraulic oil). When the hydraulic oil was dirty, stale or contaminated, it must be replaced with pure hydraulic oil without delay.

IMPORTANT: Refueling bit of oil to about 90 oil level indicator, preferably not less than 70, and not more than the maximum, to avoid hydraulic oil spill (fig2.3).



Fig2.3 Hydraulic Oil Tank

2.4 CONNECTING THE BATTERY

MODELS: DH-MODELS, DM-MODELS

A battery with breaker has been linked with the start motor of the engine. What you should do is close breaker before you starting the machine. The breaker was beside the battery which was under the diesel engine cover.

WARNING: To avoid sparks and a possible explosion or fire due to a short circuit, do not touch the positive (+) battery terminal and any surrounding metal with tools, jewelry or other metal objects.

PLEASE TURN OFF THE BREAKER WHEN TOWING OR LONG STORED THE VEHICLE.

2.5 ATTACHING THE CHIPPER CHUTE

MODELS: ALL MODELS

The chipper chute extension is an optional item for you.

Assembling the chute extension with M10 bolts, washers and nuts according to the figure 2.4

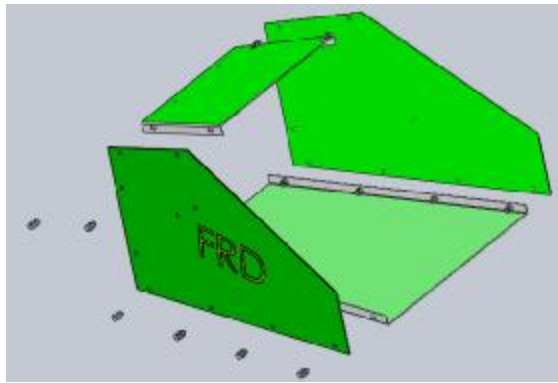

Figure 2.4 Chute Extension Assembling

Align the chipper chute extension border to chipper chute. Attach the chipper chute extension to chipper chute with four chute connection boards using eight M10 bolts, washers and nuts (Figure 2.5).

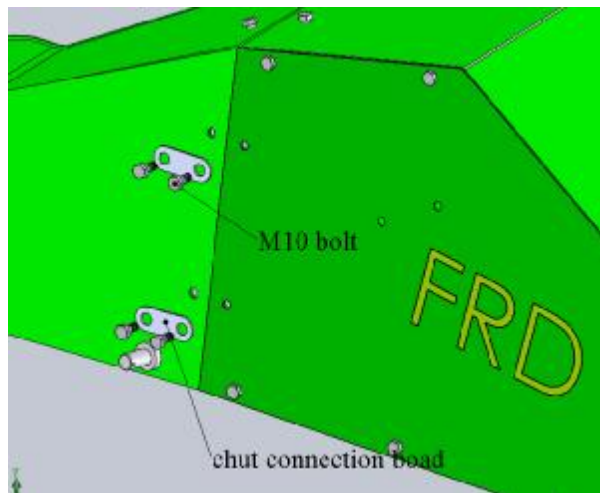

Figure 2.5 Chipper Chute Extensions

Use four M10 bolts, washers and nuts to fix the feed roller control bar on the top of the chipper chute.

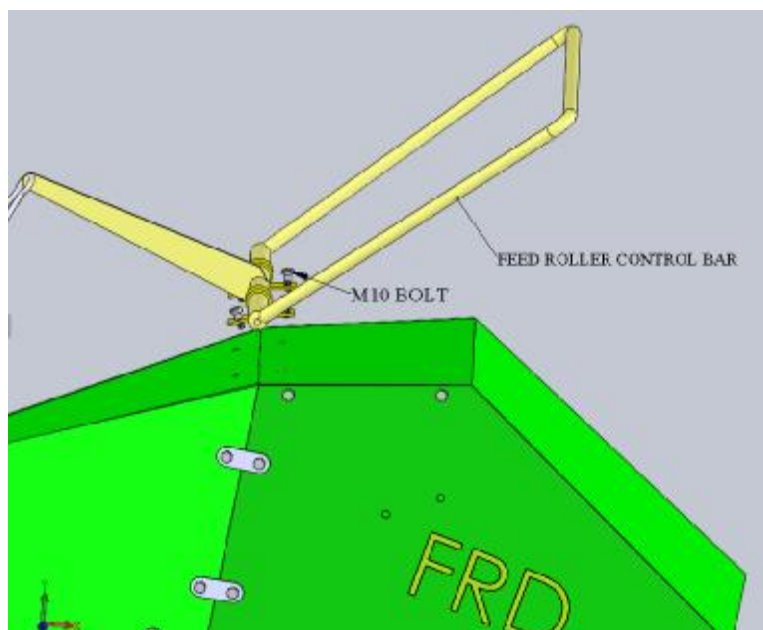

Figure 2.6 Feed Roller Control Bar

2.6 REVERSING VALVE

MODELS: TH-MODEL, DH-MODELS

Use two M10×60 bolts, washers and nuts to fix the reversing valve on the side plate of the chipper chute extension. Reversing valve and hydraulic tubing are pre-assembled at our factory (figure 2.7).

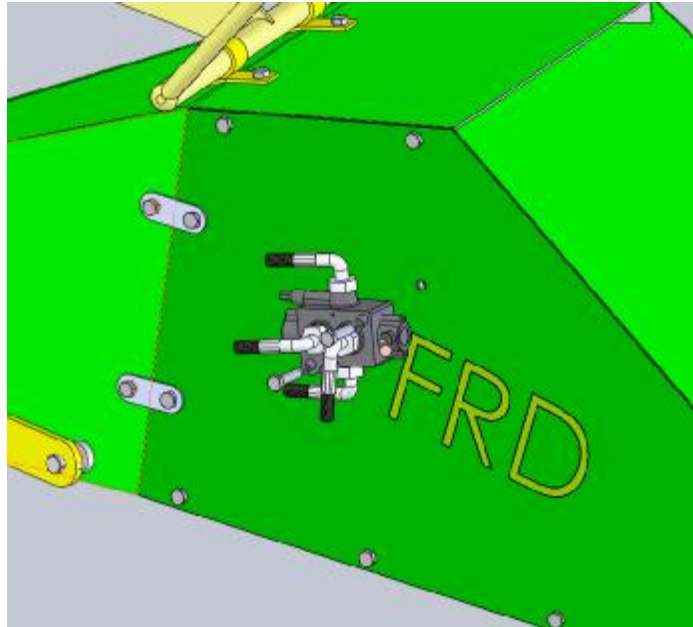
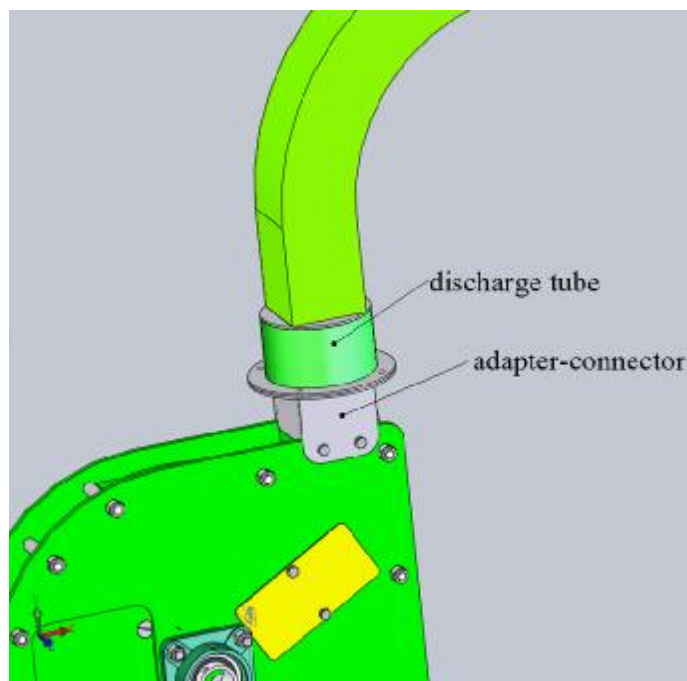

Figure 2.7 Reversing Valve

2.7 DISCHARGE TUBE

Attach the adapter-connector to the mounting flange on the chipper frame. Insert four bolts respectively (included in owner's kit) through the four sides holes and tighten the bolts to secure it.

Rotating the discharge tube to the right place, align two of the four bolt holes in the discharge tube disk cover with the two arc wall in the adapter-connector and fix them using two M10, two washers and two nuts.



3 FEATURES & CONTROLS SECTION

Understanding how your machine works will help you achieve the best results when using your chipper. The following descriptions define the features and controls of your machine.

3.1 ENGINE THROTTLE

MODELS: DH-MODELS, DM-MODELS

Changes engine speed. Push lever to 1/2 throttle for starting. Push lever to SLOW for idle and warm-up. Push throttle lever to SLOW to shut engine off. Refer to engine manual for further engine operating instructions. When chipping, the engine should be at full throttle.

3.2 KEY SWITCH

MODELS: DH-MODELS, DM-MODELS

The key switch is used to start or stop the engine.

3.3 DISCHARGE TUBE

The discharge tube can be rotated 360 degree horizontally by moving the bolts on it.

3.4 FEED CHUTE

MODELS: ALL MODELS

Materials to be chipped are fed into the feed chute, through the feed roller, to the chipper blades. On the top of the chute is a feed roller control bar. The chipper will not feed material if the feed roller control bar is pressed.

3.5 CHIPPER BLADES

The chipper blades chip material that is fed into the chipper chute.

3.6 FEED ROLLER CONTROL BAR

To engage the feed roller moves the control bar.

3.7 HITCH JACK

MODELS: DH-MODELS, DM-MODELS

Be used to adjust the height of the hitch to keep the trailer in the level position (figure3.1).



Figure3.1 Hitch Jack

3.8 SAFETY CHAINS

MODELS: DH-MODELS, DM-MODELS

Safety chains are used, during towing, to prevent the chipper from completely separating from the tow vehicle in the event

3.9 3-POINT HITCH CONNECTIONS

MODELS: TH-MODELS, TM-MODELS

Mount the chipper to the tractor using the 3 point hitch connections.

3.10 PTO SHAFT

MODEL: TH-MODELS, TM-MODELS

Connects the tractor PTO to the chipper drive shaft. Avoid an angle greater than 15 degrees up or down with the unit is in use.

4 OPERATION SECTION

As with any other piece of outdoor power equipment, getting the feel for how your machine operates and getting to know the best techniques for particular jobs are important to overall good performance.

CHIPPING OPERATION

The chipping operation takes place on the side of the machine, where hardened steel chipper blades are mounted on a rotating rotor assembly. Material fed into the chipper chute is sliced into small chips and propelled out through discharge tube. The chips can be diverted into a container or onto the ground

WARNING!

Before operating your machine, be sure you read and understand all safety, controls and operating instructions in this Owner/Operators manual and on your machine. Failure to follow these instructions can result in serious injury or property damage.

4.1 STARTING ENGINES

MODELS: DH-MODELS, DM-MODELS

Move the machine to a clear, level area outdoors before starting.

Do not operate in the vicinity of bystanders. Make sure the cutting chamber is empty before starting.

Do not crank the engine continuously for more than 10 seconds at a time. If the engine does not start, allow a 60 second cool down period between starting attempts. Failure to follow these guidelines can burn out, or permanently damage, the starter motor.

If the engine develops sufficient speed to disengage the starter but does not keep running (a false start), the engine rotation must be allowed to come to a complete stop before attempting to restart the engine. If the starter is engaged while the flywheel is rotating, damage to the starter may result.

If the starter does not turn the engine over, shut off starter immediately. Do not make further attempts to start the engine until the condition is corrected. Do not jump start using another battery. Follow the steps below to start the machine

1. Check the breaker, ensure it was connection. The breaker was beside the battery under the engine shield.
2. Check engine oil level before starting.
3. Place the throttle control midway between the SLOW and FAST positions.
4. Turn the key switch clockwise to the ON position to start the engine.
5. For a Cold Engine - Start the engine after warm up.

4.2 STOPPING ENGINES

1. Move throttle to SLOW position.
2. Shut off engine (see engine owner's manual).
3. Allow machine to come to a complete stop.

NOTE: The disk will continue to turn for some time after the engine has been shut off .Make sure disk has stopped completely before inspecting or servicing machine.

4.3 STARTING TRACTORS

MODELS: TH-MODELS, TM-MODELS

1. CONNECTING THE PTO SHAFT

Move the machine to a clear, level area outdoors before starting. Do not operate in the vicinity of bystanders. Make sure the cutting chamber is empty before starting.

Connect the PTO shaft between the chipper and the tractor. The minimum & maximum telescoping on the PTO shaft is 26" to 32".

2. Start the tractor engine and engage the tractor PTO.

3. Increase the engine speed to the rated PTO RPM position.

4.4 STOPPING TRACTORS

MODELS: TH-MODELS, TM-MODELS

1. Move the tractor throttle to the SLOW position.

2. Disengage the PTO lever and shut off the tractor engine.

3. Allow machine to come to a complete stop.

4.5 CHIPPING GUIDE

The chipper chips a variety of materials into a more readily decomposed or handled condition. The following guidelines can help you get started.

Run unit at full operating speed before starting to chip material.

These machines are most effective when chipping material 0-8" in diameter.

Trim those lateral branches that cannot be bent enough to feed into the chipper chute. Hold small diameter branches together in a bundle and feed in simultaneously.

Exclude pieces of metal, rocks, bottles, cans, and other foreign objects when feeding chip able material into the machine.

Do not lean over the chipper chute to push objects into the cutting device. Use a push stick or brush paddle.

Place limb, butt end first, into the chipper chute until it contacts the chipper blades. The actual feed rate of the limb into the chipper will depend on the type of material fed and sharpness of the cutting blades.

Stop the material feeding and allow the engine to recover if the engine slows to where it may stall.

Alternately insert and retract the limb or insert continuously at a rate that will not kill the engine.

Chipping dead, dry material will create heat and dull the chipping blades quickly.

Alternate green material with dry material can lubricate the chipping blades for longer life and better performance.

The chipping blades will become dull and will require periodic sharpening. Refer to the Service and Maintenance section for sharpening instructions.

5 SERVICE & MAINTENANCE

5.1 MAINTENANCE SCHEDULE

The items listed in the service and maintenance schedule are to be checked, and if necessary, corrective action taken. This schedule is designed for units operating under normal conditions. If the unit is operating in advance or severe usage conditions it may be necessary for the items to be checked and serviced more frequently.

SEE ENGINE OWNERS MANUAL FOR FURTHER ENGINE MAINTENANCE AND TROUBLESHOOTING INFORMATION.

SERVICE AND MAINTENANCE SCHEDULE									
Components	Maintenance	FREQUENCY							
		Before Each Use	Every 8Hrs	Every 25Hrs	Every 50Hrs	Every 100Hrs	Every 250Hrs	Every 500Hrs	Every 1 Year
Engine	Check/Fill	•							
Fuel tank	Check/Fill	•							
Battery Connections	Check	•							
Nuts & Bolts	Check		•						
Chipper Blades	Check, Sharpen If needed(3)		•						
Belt/Pulley Alignment	Check			•					
Drive Belt	Check			•					
Tire Pressure	Check				•				
Entire Machine	Clean				•				
Engine Oil	Change				•				
Cooling Shrouds	Clean					•			
Pre-cleaner Element	Clean						•		
Air Cleaner	Check/Clean						•		
Oil Filter Cartridge	Replace							•	
Fuel Filter Cartridge	Replace							•	
Starter Motor	Service							•	
Air Cleaner	Replace								•
1. Perform more frequently in dusty, dirty or severe usage conditions.									
2. Have a your engine service dealer perform this service.									
3. It is a good sign that your chipper blades need sharpening when material stops self feeding.									
4. Perform after the first 50 hours of operation.									
5. Refer to engine owner's manual for additional maintenance schedules.									

WARNING!

BEFORE INSPECTING OR SERVICING ANY PART OF THIS MACHINE, SHUT OFF POWER

SOURCE, AND MAKE SURE ALL MOVING PARTS HAVE COME TO A COMPLETE STOP.

5.2 CHIPPER BLADES

WARNING: Chipping blades are sharp! Use caution when working on machine to avoid injury.

The chipping blades will eventually become dull, making chipping difficult and adding extra strain on the machine. Poor chipping performance is usually a result of dull chipping blades. It is recommended that the blades be sharpened every 5-15 hours or if your chipper's performance has decreased. Check for the following symptoms and sharpen the blades if needed.

Severe vibration when feeding material into the chipper.

Small diameter branches do not self-feed.

Chips discharge unevenly or have strongly tails, especially when chipping green branches.

Before you sharpen the chipping blades, check for permanent damage. Replace the blade if.

1. There are cracks, broken corners or nicks.
2. The base of the cutting edge is worn or has been re-sharpened

5.3 REMOVING AND SHARPENING THE BLADES

5.3.1 Removing the blades

1. Remove the blade replaces cover from the chipper housing by loosening and removing the two M10 bolts.
2. Remove the four bolts on the back side access of disk cover.
3. Rotate the disk so that the bolts holding the chipper blades are accessible.
4. Install the chipper blades and cover carefully.
5. Inspect blades to see if cracks or nicks are visible. If cracks are present, replace the blades. If nicks cannot be removed by sharpening blade, replace the blade.

5.3.2 SHARPENING THE BLADES

1. Never sharpen or grind the mounting surfaces of the blades. This will cause the edge to roll and the blade will be damaged, resulting in poor chipping performance.
2. Regrind the angled edge of the chipping blades to 30~32 degrees (Figure 5.1).
3. The blades can be ground on a bench grinder or by a professional.
4. Make sure some type of fixture is used to correctly hold the blade at the proper angle.
5. Be careful when grinding so that the blade does not become overheated and change color. This will remove the heat treated properties.
6. Use short grinding times and cool with water or some type of liquid coolant.
7. Remove an equal amount off each blade to maintain rotor balance.
8. Small imperfections such as nicks and burrs on the flat side of the blade will not affect the chipping performance of the machine.
9. For blades that have been repeatedly sharpened, ensure that the sharpened surface extends past the chipping slot opening. If it does not extend past the opening, the blades should be replaced.

5.3.3 INSTALLING THE BLADES

1. Place a blade on the disk and attach with three M10 Countersunk head hex bolts and three M10 locknuts. Torque the bolt to **75 foot-pounds**. Repeat for the remaining blades.

The chipping blades should clear to the disk surface, by least 2mm. To adjust (increase) the blade clearance, 1-3mm aluminum sheet can be placed under blades to the size of the debris. But the chipping blades should clear to the chipping anvil, located directly under the chipper chute, by least 1.5mm meanwhile (Figure 5.2).

It is important to ensure that the minimum gap between the chipping anvil and ALL chipping blades is

1.5mm. Failure to do so can result in the chipping blades striking the chipping, causing serious injury or death.

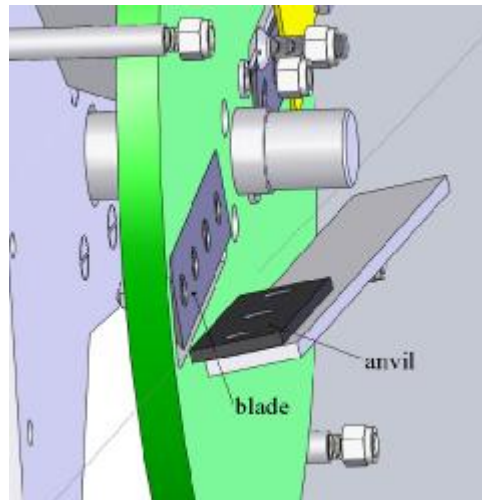

Figure 5.2

2. Reinstall the blade replaces cover.

5.5 DRIVE BELT ADJUSTMENT

Check the condition of the drive belt(s) annually or after every 25 hours of operation, whichever comes first. Replace a cracked, frayed, worn or stretched drive belt. Only replace drive belt with original banded type belt. Do not use single type belts. To adjust the drive belt(s), proceed as follows:

DH-MODELS; DM-MODELS

1. Shut engine off.
2. Loosen the three M16 bolts attaching the chipper disk housing to the trailer.
3. Tighten the adjustable bolt to increase tension on the belt.
4. Tighten the three M16 bolts attaching the chipper disk housing to the trailer (figure 5.3).

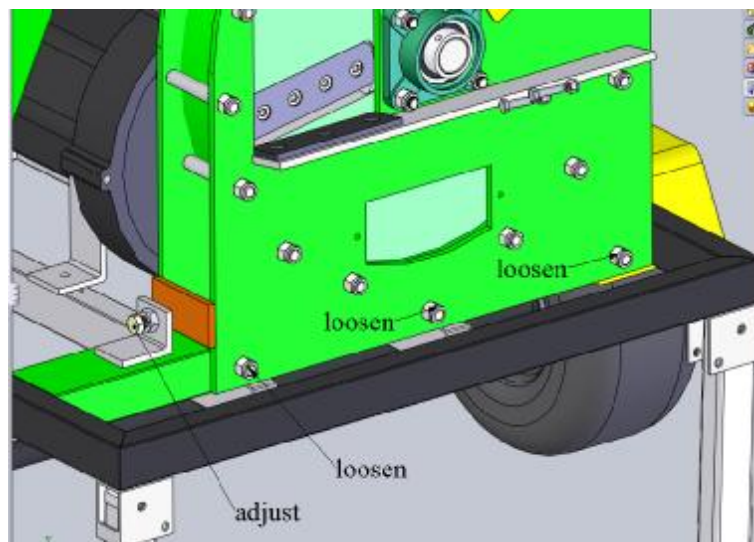
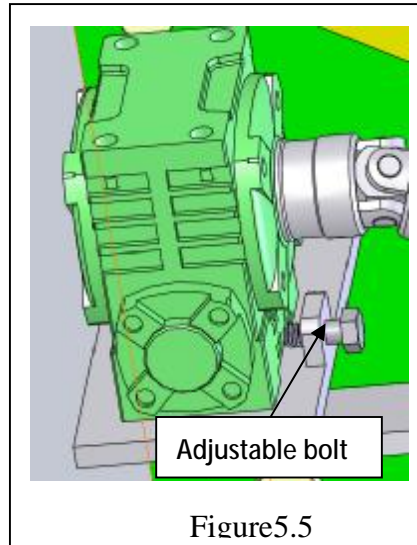
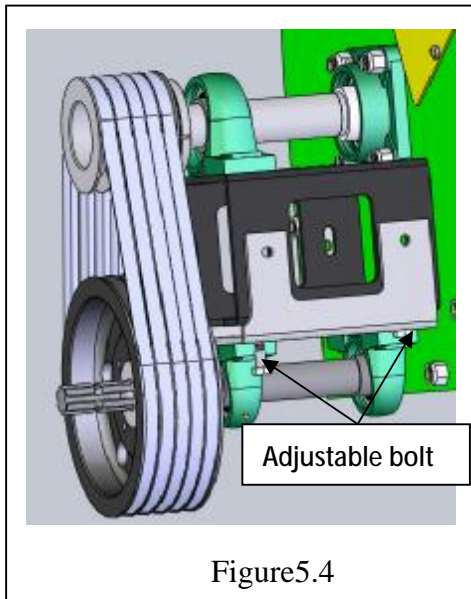

Figure 5.3 Adjust Drive Belts

TH-MODELS; TM-MODELS

The main drive belts on the chipper need to be tight. To tighten these belts may by tightening the four adjustable bolts under the bottom of the power-input-shaft bearing support. Keep the power-input-shaft parallel with the main shaft. Torque the bottom bolts 80 foot pounds (Figure5.4).



TM-MODELS; TM-MODELS

The feed roll drive belt can be adjusted by first loosening the four bolts that hold the worm gear box to the base, then moving the gear box away from the adjustable bolt and re-torques the bolts to 40 foot pounds.

5.6 TRAILER SERVICE TIPS

1. Check wheel bolt torque every 8 hours of towing.
2. Check air pressure in tires every 8 hours of towing. Inflate to pressure marked on sidewall of tire.
3. Check and repack wheel bearings with grease every 12 months.
4. When towing, use a proper size ball, and always connect the safety chain, make sure trailer hitch bolts are tight and secure.

5.7 GREASING THE BEARINGS AND PIVOTS

Mounted bearings are pre-lubricated at our factory and are ready for operation.

RELUBRICATION: Relubrication of bearings is determined by operating conditions and environment. Relubricate standard bearings with a LITHIUM based grease.

GREASING INTERVALS: Bearings in extreme environments will require more frequent greasing intervals.

Care should be taken when greasing bearings to avoid overfilling.

Overfilling can lead to excessive heat and or unseating of the seals. Grease should be introduced in small increments and under light pressure. Whenever possible, the bearing should be rotated slowly while grease is being added to ensure equal distribution throughout the raceways.

6 TROUBLESHOOTING SECTION

Before performing any of the corrections in this troubleshooting chart, refer to the appropriate information contained in this manual for the correct safety precautions and operating or maintenance procedures. Contact your nearest dealer or the factory for service problems with the machine.

PROBLEM	POSSIBLE CAUSE	REMEDY
---------	----------------	--------

Engine will not start.	Improper control settings. Lack of fuel. Dirty, stale or contaminated fuel. Internal engine problems.	Use proper settings. Fill fuel tank. Refill tank with fresh, clean fuel. See your dealer.
Engine or disk stalls or stops.	Obstructed discharge. Plugged disk.	Use branch or similar object to clean discharge. Clear disk. Feed material more evenly.
Hard to feed chipper, requires excessive power to chip.	Dull chipper blades. Obstructed discharge. Improper blade clearance.	Rotate or sharpen blades. Use branch or similar object to clear discharge. Adjust clearance between the chipper blades and anvil
Material from chipper wraps around disk shaft.	Stringy, green material bypasses chipper blades. Dull chipper blades. Improper blade clearance.	Rotate branch or material when feeding to cut completely. Sharpen blades. Adjust clearance between the chipper blades and anvil.
Excessive vibration while running.	Drive system vibration. Disk out of balance. Chipper blade/anvil clearance is incorrect.	Check for dull chipper blades. Inspect disk for broken or missing chipper blades, replace if needed. Check disk to see if it wobbles. Check to see if disk is assembled correctly. Set chipper blade/anvil clearance to recommended distance.
Disk will not turn.	Obstructed discharge. Plugged disk.	Use branch or similar object to clear discharge. Clear disk. Feed material more evenly.
Trailer sways during towing.	Tire air pressure not correct	Check tire sidewall for inflation limits.

7 SPECIFICATIONS SECTION

SIZE SPECIFICATIONS

MODEL	DH- MODEL	DM- MODEL
Max. Dia. of Feeding	8 "	8 "
ENGINE Power	CE CERTIFICATE Diesel 480/385 (40/30hp, 4 Cylinder, 2000rpm)	CE CERTIFICATE Diesel 1105 (18hp, 1 Cylinder, 2000rpm)
Diameter of Chipper Disk	600mm	600mm

Turning Speed of Chipper Disk	1025rpm	
Feeding System	Hydraulic Feeding, Adjustable Speed, Stop-Reverse-Forward Function	Feeding by Worm Reduction Gear (4mm/s) Only Forward Function
Blade Quantity	2 OR 4(Not to Be Recommended)	
Sawdust Measurement	Thickness<4mm	
Rotation Angle of Discharge Spout	360	
Weight	640kg (Include Package)	570kg (Include Package)
Working Efficiency	8~9m ³ /h	7~8m ³ /h
Volume of TANK	26L	/
PACKAGE DIMENSIONS (L×B×H) (mm)	1730×1360×1360 1730×1080×1360 (Assemble Without Axle)	1350×1360×1360 1350×1080×1360 (Assemble Without Axle)

Model	TH- Model	TM- Model
Max. Dia. of Feeding	8 "	
POWER	Tractor (25~45hp, 540/720rpm)	
Diameter of Chipper Disk	600mm	600mm
Turning Speed of Chipper Disk	1080rpm/1410rpm	
Feeding System	Hydraulic Feeding, Adjustable Speed, Stop-Reverse-Forward Function	Feeding by Worm Reduction Gear (4mm/s) Only Forward Function
Blade Quantity	2 OR 4(Not to Be Recommended)	
Sawdust Measurement	Thickness<4mm	
Rotation Angle of Discharge Spout	360	
Weight	450kg	420kg
Working Efficiency	8~9m ³ /h	7~8m ³ /h
Volume of TANK	38L	/
PACKAGE DIMENSIONS (L×B×H) (mm)	1110×850×1350	1110×800×1350

8. PRODUCT PATENT:

ZL200830017359.5, ZL 200820026689.5, ZL200830017360.8 and ZL201020015258.6 are used in the chipper.